

## SEU304EMTB

70CM (30") Ceramic Cooktop  
Black Glass, Beveled

EAN13: 8017709240981

5 high-light radiant zones:

Front-right: Ø 5 ½" (140mm) Booster 1,200W

Back-right: Ø 7 5/8" (195mm) Booster 2,000W

Central: Ø 5 ½" - 8 ¼" - 10 5/8" (140-210-270mm)

Booster 750+900+1,050W

Back-left: Ø 5 ½" (140mm) Booster 1,200W

Front-left: Ø 4 ¾" - 7" (120-180mm) Booster  
800+1,200W

Soft-touch controls

5 high-light radiant elements, including 2 variable  
zones  
(central zone with three-level adjustment)

9 power levels for each zone

Residual heat indicator for each zone

Automatic safety cut-out

Individual timer for each zone (1 - 99min)

Child safety lock

Voltage rating: 240/208V 60Hz

Connected load (nominal power): 240/208V -  
8.6/6.5 kW -  
36/32 Amps

Electrical - single phase 3 or 4-wire cable required,  
60Hz, fused on both sides of line with ground

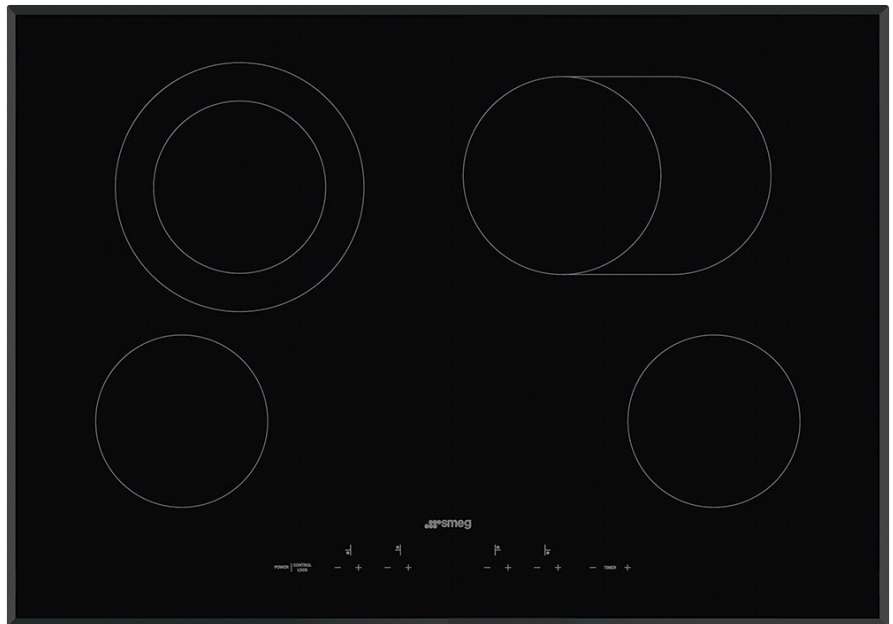



# SEU304EMTB

ceramic cooktop  
30"  
black  
touch control

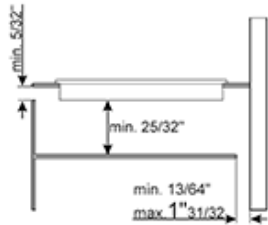
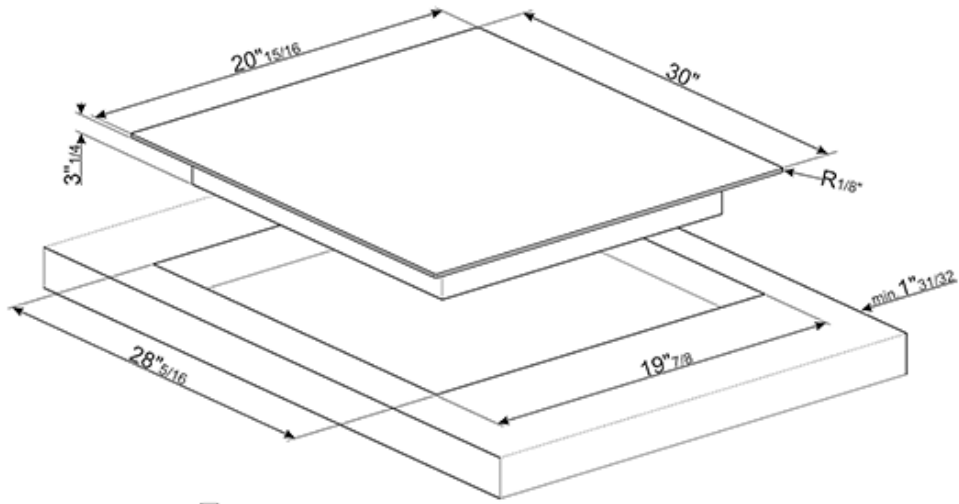

SMEG U.S.A. INC.  
A&D BUILDING  
150 EAST 58th STREET, 7th FLOOR  
NEW YORK, NY, 10155  
Tel. +1 212 265 5378  
Fax +1 212 265 5945